

System Design and Experimental Evaluation of a MEMS-based Semicircular Canal Prosthesis

Jiayin Liu*, Andrei M. Shkel * †, Kaibao Nie †, and Fan-Gang Zeng † ‡

*Department of Mechanical and Aerospace Engineering

†Department of Biomedical Engineering

‡Department of Otolaryngology-Head and Neck Surgery

University of California, Irvine, CA, USA

jiayinl@uci.edu, ashkel@uci.edu, knie@uci.edu, fzeng@uci.edu

Abstract—This paper presents a functional architecture, system-level design, and preliminary experimental evaluation of a unilateral vestibular prosthesis. The sensing element of the prosthesis is a one-axis MEMS gyroscope. Similarly to the natural semicircular canal, the microscopic gyroscope senses angular motion of the head and generates voltages proportional to the corresponding angular accelerations. Then, voltages are sent to the pulse generating unit where angular motion is translated into voltage pulses. The monophasic voltage pulses are converted into biphasic current pulses and are conditioned to stimulate the corresponding vestibular nerve branch. Our preliminary experimental evaluations of the prosthesis on a rate table indicate that the device's output matches the average firing rate of vestibular neurons to those in animal experiments reported in the literature. The proposed design is scalable; the sensing unit, pulse generator, and the current source can be potentially implemented on a single chip using integrated MEMS technology.

Keywords - Neural vestibular prosthesis, artificial implants, inertial MEMS applications

I. INTRODUCTION

Sensory prosthesis to artificially replace lost sensory function for a number of sensory systems are currently under investigation. For example, cochlear implants use electrical stimulation to restore hearing and provide some relief for patients suffering profound sensorineural hearing loss [1]. Using similar principles of stimulation, a vestibular prosthesis could provide head orientation information to the nervous system for patients suffering from peripheral vestibular disorders.

At least two categories of vestibular prosthesis might be considered. One approach is to provide the head movement information to the nervous system directly by electrically stimulating the vestibular neural pathways related to spatial orientation. Another approach is to provide the information via sensory substitution through other sensory systems (e.g., tactile, visual, auditory, etc.) [2]. This work falls in the first category. Our goal is to develop an implantable, vestibular neural prosthesis using electrical stimulation. To the best of our knowledge, there is only one group working on neural semicircular canal prosthesis that has already reported successful interface of the device with vestibular neurons [3]. In the reported implementation, an off-the-shelf single axis

piezoelectric vibrating gyroscope was used to measure the head rotation and a microcontroller was used to convert rotational information into electrical pulsatile stimulus to provide corresponding stimulus to the nervous system.

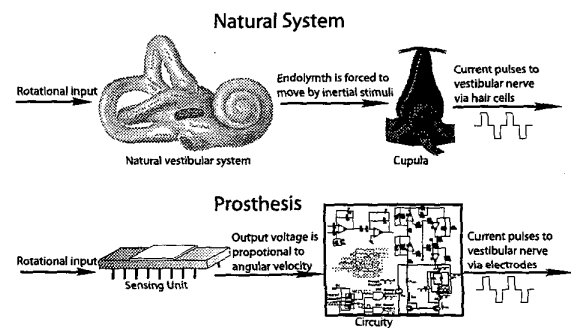

Fig. 1. MEMS-based neural vestibular prosthesis is mimicking functionality of the natural vestibular end-organ

In contrast, our approach is based on a custom design of sensors using the MEMS technology and a custom analog/digital design of the pulse generating unit converting rotational information into electrical stimulus, Fig. 1. The proposed design can potentially integrate sensors alongside with control electronics on the same silicon chip in a volume smaller than 1 cubic centimeter. Such "balance on-a-chip" system might potentially replace the function of the damaged vestibular end-organ by providing 3-dimensional motion information for people who have permanently lost peripheral vestibular function.

II. VESTIBULAR SYSTEM AND FUNCTION

The properly functioning vestibular system is responsible for a number of reflexes and reactions critical for achieving and maintaining equilibrium of the body and stabilization of images on the retina as the head and body are moved. The vestibular system comprises the non-acoustic portion of the inner ear and consists of three semicircular canals and two otolith organs called the utricle and the saccule. The sense organs of the semicircular canals detect rotational head movements, while the sense organs of the saccule and utricle

detect linear movements of the head. All of these organs have small sensory hair cells that send pulses through the nerves to the brain, where information about head movement is combined with information from the eyes, muscles, and joints, which is then interpreted.

The rotational perceptual threshold in humans was determined to be between $0.1^\circ/sec$ and $2^\circ/sec$ [4]. It should be noticed, however, that perceptual thresholds are different for different rates of acceleration and vary from person to person. Montandon [5] determined that the threshold is $1^\circ/sec^2$ in healthy individuals, but greater than $6 - 7^\circ/sec^2$ in patients with vestibular dysfunction. The reported sensation limits set the sensitivity requirements for the vestibular prosthesis.

Another critical physiological parameter is the firing rate of neurons and relation of the firing rate to the head rotation/translation. The average firing rate of regular vestibular afferents has been reported as 60 spikes/sec in the guinea pig [6] and 90 spikes/sec in the squirrel monkey [7]. The firing frequency increases when a semicircular canal responds to rotation in one direction, and decreases in the other direction. In the guinea pig, the average sensitivity is roughly 0.3 spike/s per $1^\circ/sec$ for regular afferents and 0.7 spike/s per $1^\circ/sec$ for irregular afferents [6]. These experimental results set the requirement for the pulse generating unit of the prosthesis determining the rate of electrical stimulation delivered to the vestibular nerve.

III. SYSTEM DESIGN

The purpose of the semicircular canal prosthesis is to restore balance function. The prosthesis should be able to sense motion with sufficient precision and to deliver information to the central neural system in the same form as the natural organ would transmit. In our implementation, the device includes three main functional units - a sensing unit, a pulse generator, and a stimulator [8].

A. Sensing Unit

The proposed unilateral neural prosthesis is utilizing a single-axis MEMS gyroscope. The technology allows to shrink the sensors size by orders of magnitude, reduce the fabrication cost significantly, and allow the electronics to be integrated on the same silicon chip. Potentially, an ensemble of six inertial MEMS sensors required to measure six-degrees of freedom of the head motion, can be built on a single silicon chip and packaged in a volume smaller than 1 cubic centimeter. Review on technology of inertial sensors on-a-chip can be found in [9].

For the demonstration purposes we use a single chip experimental prototype of a yaw rate sensor from Analog Devices, Inc. (Model ADXRS150). The power supply for this sensor is 4.75V to 5.25V. The scale factor of the sensor is $12.5mV/(\circ/sec)$ and the linearity is better than 1% full scale over the range of $\pm 150^\circ/sec$.

The gyroscope is sensing any type of angular rotation (constant or non-constant angular velocities), while the natural vestibular organ is only responding to the angular acceleration. Thus, in order to mimic the natural organ, the supporting circuit electronically differentiates the output voltage from the gyroscope to produce a signal proportional to the angular acceleration. In our implementation, the circuit is utilizing a low-pass filter before the differentiator for minimizing the effect of high-frequency noise.

B. Pulse Generator

The gyroscope detects motion of the head and sends corresponding analog voltage signals to a pulse generator. The pulse generator consists of a transfer function unit emulating the natural vestibular organ, Fig. 2, and a Voltage-to-Frequency converter.

The transfer function emulating dynamics of the natural vestibular organ is modeled as a linear torsion-pendulum system. In this model, the cupula and endolymph are treated as a heavily damped, second-order linear system. A more complex linear model defining the relationship between the input angular acceleration and the overall change in firing rate of neurons is described by the transfer function

$$H(s) = \frac{\tau_A s}{1 + \tau_A s} \cdot \frac{1 + \tau_L s}{(1 + \tau_1 s)(1 + \tau_2 s)} \quad (1)$$

where τ_1 and τ_2 are two time constants of the pendulum model, τ_A is related to the level of neuron adaptability, and τ_L is the dynamical-electrical time constant [7].

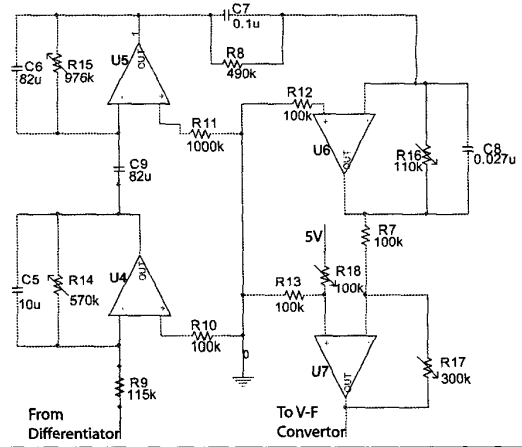

Fig. 2. Transfer function mimicking dynamics of the semicircular canals of the squirrel monkey model (reported in [7])

Experimentally obtained results in [7] for the squirrel monkey model estimate $\tau_1 = 5.7sec$, $\tau_2 = 0.003sec$, $\tau_A = 80sec$, and $\tau_L = 0.049sec$. We use these experimentally defined time-constants for the design of equivalent circuit, Fig. 2.

Four operational amplifiers are used to implement the transfer function relating the input angular acceleration to the frequency shift from the rest firing rate of the vestibular neurons (the firing rate when there are no rotational stimulus). The transfer function is separated in three parts: $H(s) = H_1(s) \cdot H_2(s) \cdot H_3(s)$. The components of the transfer function H_1, H_2 , and H_3 are defined by the operational amplifiers, U_4, U_5 , and U_6 in Fig. 2, respectively. The transfer function produces voltages proportional to the shift from the rest firing rate of vestibular neurons. An additional operational amplifier U_7 is used after the transfer function $H(s)$ to adjust voltages corresponding to the rest firing rate and sensitivity.

A Voltage-to-Frequency (V-F) converter (AD537) is used to convert the voltage signals corresponding to the shift from the rest firing rate to the equivalent frequency pulses. The corresponding input/output relationship is [10]

$$F_0 = \frac{V_{IN}}{10R_{19}C_{10}} \quad (2)$$

In our implementation we select $R_{19} = 10k\Omega$ and $C_{10} = 0.1\mu F$, resulting in $F_0 = 100 \cdot V_{IN}(Hz)$. The output is binary - 0 Volt (OFF) and 5 Volt (ON), and the duty time is 50%.

C. Current Source

The current pulses sent via neural network to brain are delivered by ion flow, so that the total charge sent to the nerve should be zero. Since tissue impedance is always changing over time, a voltage source may not maintain constant current for charge delivery. Thus, a stimulation with current source, instead of a voltage source, is required to transmit signals via neurons. The overall charge sent to brain should be zero (e.g., [1]), so that the integration of the current over time should be also zero. If this condition is not satisfied, the stimulated neurons could be destroyed. In order to satisfy these constraints, monophasic voltage signal has to be changed to biphasic current signal, Fig. 3.

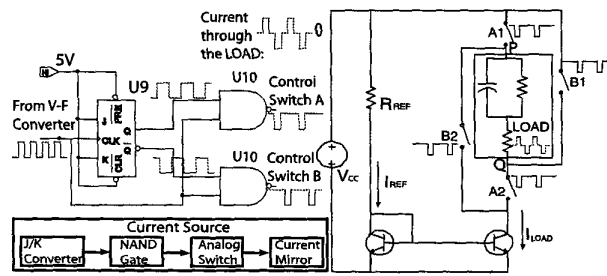

Fig. 3. "Current mirrors": convert monophasic voltage to biphasic current pulses

The biphasic current stimulus is produced from the monophasic voltage signal from V-F converter by using four components: J/K converter, NAND logical gates, analog switches, and current mirror, Fig. 3. The left side of Figure 3 shows a J/K Flip-Flop (U_9 , 74LS73) followed by two NAND Gates (U_{10} , CD4093BE). The clock (CLK) for the

J/K converter comes from Voltage-to-Frequency converter, so that the clock frequency is proportional to the firing rate and corresponds to the rotations sensed by the gyroscope. The J and K input are all high voltages (5V), so that the output Q toggles when there is a "Rising Edge" trigger in the clock. It means that the frequency of the output Q, \bar{Q} , is half of the input clock (CLK). The logic gates for the control signal of analog switches are switch $A = CLK \cap \bar{Q}$ and switch $B = CLK \cap Q$. Analog switches (U_{11} , CD4053) use these two control signals to manage the connectivity of switches A_1, A_2, B_1 , and B_2 .

The right side of Fig. 3 shows the current source configuration when A_1 and A_2 are connected, and B_1 and B_2 are disconnected, forming a typical current mirror with $I_{LOAD} \approx I_{REF}$ (holding when the condition $R_{LOAD} < R_{REF}$ is satisfied). Since V_{CC} and R_{REF} are fixed in the design, the corresponding I_{REF} is guaranteed to be fixed. When A_1 and A_2 are connected, and B_1 and B_2 are disconnected (low control voltage makes the switch connected and high control voltage makes the switch disconnected), the current flows from P to Q, Fig. 3. In contrast, when A_1 and A_2 are disconnected, and B_1 and B_2 are connected, the current flows from Q to P. When all the four switches are disconnected, there will be no current flow through the load. Such scheme of analog logical switches allows to convert monophasic voltage signal to biphasic current signal. In the proposed design, the amplitude of I_{LOAD} may be changed by adjusting R_{REF} .

The electrical properties of biological tissue are usually modeled by an equivalent circuit as a resistor and a capacitor in parallel, plus a resistor in series. The values of the resistors and capacitor in this model are fluctuating. By using the "current mirror" illustrated in Fig. 3, the voltage across the LOAD may change due to changes in impedance of the tissue, however the design guarantees that the current through the LOAD will not be affected.

IV. EXPERIMENTAL RESULTS

Performance of the unilateral vestibular prosthesis was compared to the experimentally obtained results in [7] on a squirrel monkey model. In the experiment the animal was mounted in a structure, so that the center of the head was coincident with the axis of rotation and the horizontal canal is in horizontal plane. Sinusoidal rotations with frequency 0.1 – 8Hz were sequentially applied and the response of neurons firing in the vestibular nerve were monitored and recorded. In our experiment, we initially placed our prototype of the prosthesis on a rate table and applied a constant rotational input. This allowed us to build the input/output curve for the gyroscope. Next we modeled the response of the gyroscope under the same rotational conditions as those reported in [7]. The resulting angular accelerations were used as an input to the pulse generator. A fragment of the prosthesis response to inertial stimulus is illustrated in Fig. 4

The continuous line in Fig. 4 is a sinusoidal input rotation

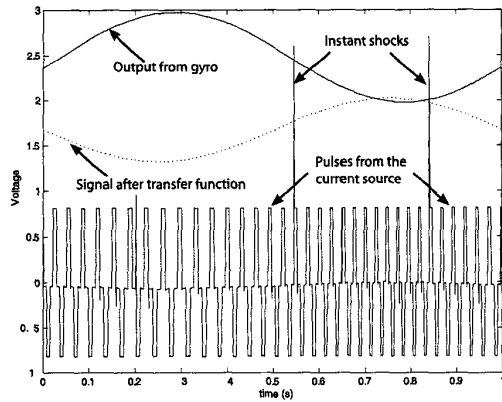

Fig. 4. Response of the prosthesis to the harmonic inertial excitation

of the rate table as it were measured by the sensing unit (gyroscope) of the prosthesis. The dashed line is the analog signal after the input from the gyroscope was fed through the transfer function of the pulse generating unit. The fixed amplitude pulses are superimposed in the same figure to illustrate dependence and similarity of the signal provided to the vestibular nerve by the natural vestibular system and by the vestibular prosthesis. For the illustration purposes the input rotation was harmonic with the frequency 1Hz and with maximum acceleration $250^0/\text{sec}^2$. The output biphasic current pulses generated by the prosthesis were 40 spikes/sec for the resting firing rate, with maximum at 50 spikes/sec and minimum at 30 spikes/sec. Note that the resting firing rate and sensitivity can be easily scaled using the amplifier U_7 . Instant shocks in Fig.4 can be attributed to the conversion of the digital signal to analog signal. Such short-term shocks are unavoidable and can be minimized by adding a small capacitor parallel to the load.

In Fig. 5 we provide a side-by-side comparison between the experimental results on squirrel monkey [7] and the designed vestibular prosthesis. The comparison is performed for the harmonic angular acceleration with frequencies between 0.1 Hz and 8 Hz. The gain results demonstrate a very close match between two experiments, however there is a slight phase shift between the data obtained from the prosthesis and the animal experiment. Our future design will incorporate an all-pass filter for compensation of the phase shift.

V. CONCLUSION

We have developed a prototype of one-dimensional neural vestibular prosthesis based on MEMS gyro technology. From the experimental results (presented here and compared to those in the literature), it is clear that this prosthesis can provide a rotational cue to the nervous system. Our design is scalable and can be integrated on-a-single iMEMS chip.

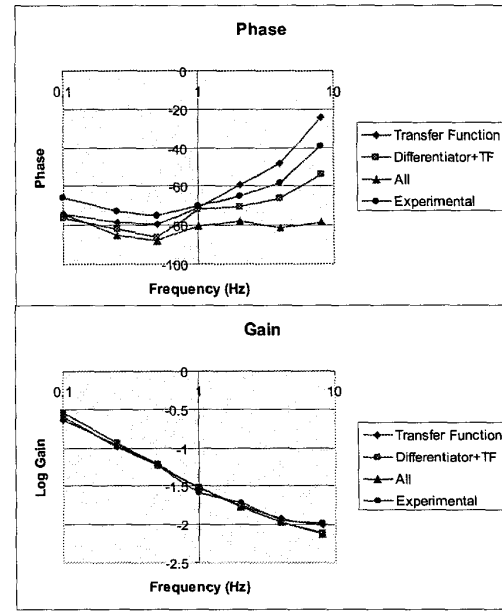

Fig. 5. Performance of the vestibular prosthesis and comparison with experimental vestibular response of squirrel monkey

ACKNOWLEDGMENT

This project was partially supported by UC MEXUS-CONACYT Grant for Collaborative Projects, Grant Number CN-02-70.

REFERENCES

- [1] S.U. Ay, F.-G. Zeng, and B. Shen, "Hearing with Bionic Ears," *IEEE Circuits and devices*, vol. 5, pp. 18–23, 1997.
- [2] M. Weinberg, J. Borenstein, J. Connelly, A. Kourepenis, P. Ward, and J. Heiertz, "Application of Draper/Boeing micromechanical inertial instruments," *Sensors Expo '98*, vol. CSDL-P-3673, 1998, oct., Chicago, IL.
- [3] W. Gong and D. Merfield, "System design and performance of a unilateral horizontal semicircular canal prosthesis," *IEEE Trans. Biomed. Eng.*, vol. 49, pp. 175–181, Feb. 2002.
- [4] A. Benson, "Thresholds for the perception of whole body angular movement about a vertical axis," *Aviat., Space Envi-ron.Med.*, vol. 60, pp. 205–213, 1989.
- [5] A. Montandon, "A new technique for vestibular investigation," *ACTA Otolaryngology*, vol. 39, p. 594, 1954.
- [6] I. Curthoys, "The response of primary horizontal semicircular canal neurons in the rat and guinea pig to angular acceleration," *Exp. Brain Res.*, vol. 47, p. 286294, 1982.
- [7] J. M. Goldberg and C. Fernandez, "Physiology of peripheral neurons innervating semicircular canals of the squirrel monkey. II. Response to sinusoidal stimulation and dynamics of peripheral vestibular system," *J. Neurophysiol.*, vol. 34, pp. 661–675, 1971.
- [8] A. M. Shkel, J. Liu, C. Ikei, and F. Zeng, "Feasibility study on a prototype of vestibular implant using MEMS gyroscopes," in *Proc. IEEE Int. Conf. on Sensors*, Orlando, FL, U.S.A., June 2002, paper 55.1, pp. 1526–31.
- [9] A. Shkel, "Micromachined gyroscopes: Challenges, design solutions, and opportunities," *2001 SPIE Ann. Int. Symp. on Smart Structures and Materials*, 2001, march, 2001, Newport Beach, CA.
- [10] I. Analog Devices. (2000) Ad537 reference data sheet. [Online]. Available: <http://www.analog.com>